

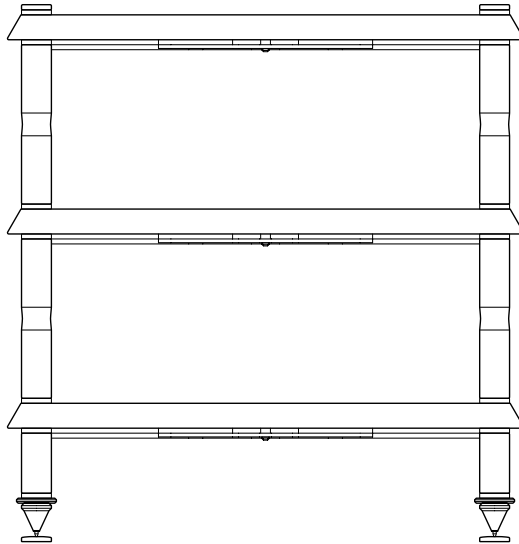

MODULUM



THE MULTILEVEL PLATFORM

Assembly Instructions



Congratulations for purchasing this Modulum instrument.
It is designed to maximize the performance of all audio components.
You will now be able to enjoy your system to it's full potential.

Happy listening,

The Modulum team.

IMPORTANT

METAL DIFFERENCES

The parts that you have to assemble are made of aluminum, but the screws are made of steel. Given that aluminum is a softer metal than steel, you must be very careful and sometimes patient when assembling all the parts.

We want to be sure that the black rubber washers are securely tightened around the screws. This means that small particles of rubber could become detached and stuck in the threads of the screws, creating a certain resistance as the screws are tightened. This shouldn't pose a huge problem. Just proceed with a light touch and make sure that the screw is well engaged with the threads of the aluminum part.

SCREW TIGHTENING

Never force a screw. If you're encountering a little difficulty, you can cover the end of the screw or the inside of the nut with a bit of candle wax or all-purpose oil. You should know that after hundreds of assemblies, we have yet to fail, although a certain amount of patience and a delicate touch have sometimes been necessary.

You should also know that it is not advisable to tighten everything to the maximum during assembly. That's because between each of the assembled parts there's a rubber washer, and once it's slightly compressed, it offers sufficient resistance for a solid assembly. It's also a wise idea to occasionally check to see if the entire assembly remains securely and sufficiently tightened.

HARMONIC ABSORBERS

Harmonic absorbers have been preinstalled under each shelf. These absorbers are fixed to the shelf by a single Allen screw. You mustn't tighten this screw more than is necessary. The absorber must stick to the shelf and not offer more than a certain resistance if you try to make it pivot with your finger. You should check to make sure that the absorbers remain parallel and sufficiently tightened.

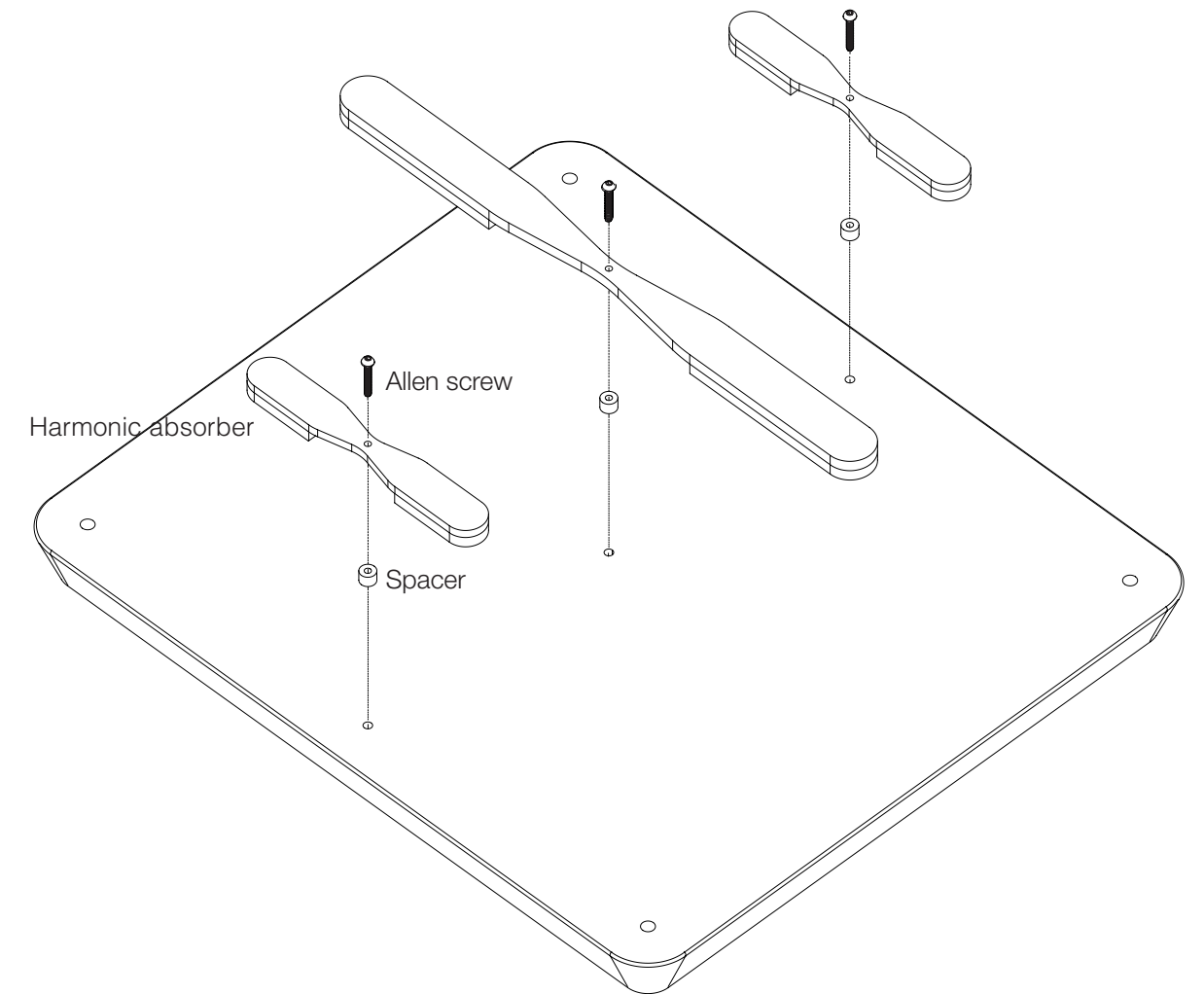

ASSEMBLY

a) Assemble the spikes and the 3" columns by screwing on a ring and inserting a washer between the ring and the column. Screw a 2 1/2" compression screw to the end of each of the 3" columns and slide a washer onto the end of each screw.

b) Take a shelf and stand it upright on its longest side. Insert the first two spike/column assemblies in the holes closest to the floor. The shelf should be able to stand upright supported by the first two spikes. Put in the two other spike/column assemblies and put the shelf on the floor, resting on its four spikes.

c) Screw in four columns (10" or 8"), first making sure to insert washers between the columns and the shelf. At the end of each column screw on a 2 1/2" compression screw. Slide a washer onto the end of each of these.

d) Put on a second shelf, making sure to align it correctly and thus avoid scratching the underside of the shelf. Slide washers onto the end of each of the four compressions screws.

e) Screw in four more columns (10" or 8"). If the third shelf is the last for your module, put washers on the end of each of the columns before putting the shelf in place. To secure this last shelf, assemble four allen head end screws by putting together an end ring and a washer. Put each of these end screws in one of the four holes in the shelf. (Hint) It is advisable to screw in the first two screws on a diagonal angle. Insert the first screw through the shelf and put a washer on the end of it, making sure to tighten it well under the surface of the shelf. Screw in the screw only about a quarter of the way in order to leave some play to insert the other three screws. Finish the operation by tightening the four screws all the way -- and you're done!

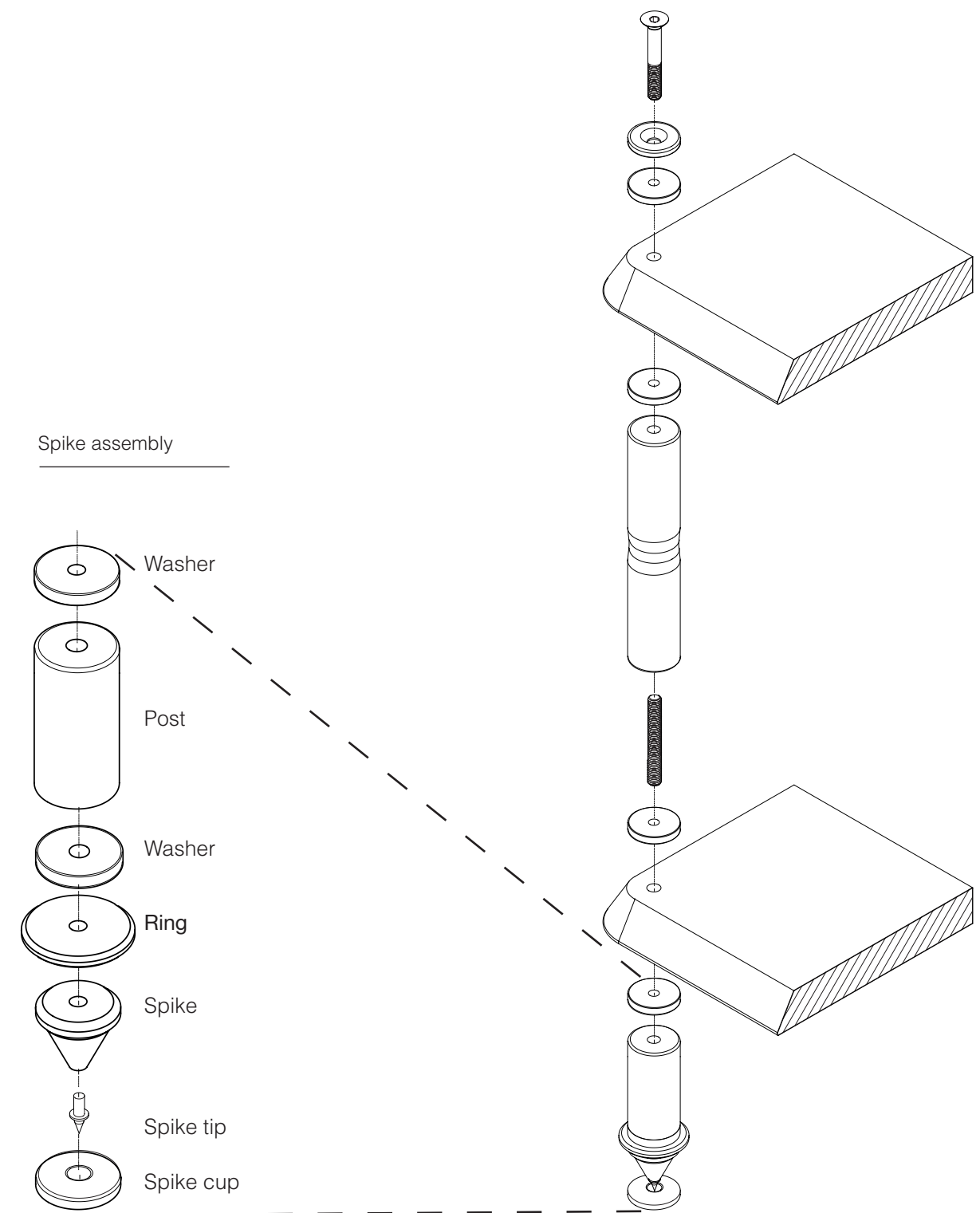



MODULUM

We rely on Modulum platforms and modules



Modular
Frequency
Modulable
High-End Audio
Platforms
& Furniture

671, Logan Street
Saint-Lambert (Quebec) JfourP 1K5
CANADA
+1. 51four.915.5060
jfmichaud@modulum.ca

modulum.ca